



Price List Contents

Page

New	Prepackaged Power Tool Kits	2
	Flexible Shaft Power Tools	2 - 5
New	Handpieces	6 - 7
	Speed Controls, 220/240 Volt Control Power Cords and Plugs	8
	Maintenance Supplies	8
	Handpiece Collets and Accessories	9
New	Bur Holders, Safety Glasses, On/Off Foot Switch	10
New	Motor Hangers	11
	Drill Presses, Multi-Angle and Mini Vises	12
	Bench Lathe, High Speed Bench Grinders, Flexade®	13
	PowerGraver® Kit and Sharpener/Honer with Fixture	14 - 15
New	Micro Motor Kits and Components	16 - 17
New	Allset™ Stone Setting and Drilling Guides	18
	Air Turbine and Air Grinder	19
	Product Repair and Warranty Information	Back Cover

Flexible Shaft Power Tool Selection Guide

Series	Special Features	Motor Horse-Power	Maximum No Load Speed (RPM)	Hang Up Model	Bench Model	Speed Control Options See Page 8		Bench Model with Built-in Speed Control	See Page
						Foot	Manual		
H	Heavy-Duty Industrial Model	¼ HP	20,000	H	HB	SCH, FCH	EMH	HM	3
S	Powerful-All Purpose Model	⅛ HP	18,000	S	SB	FCT, SCT	EM	SM	4
SR	Same as "S" with Reversing feature	⅛ HP	18,000	SR	SRB	FCT, SCT	EM	SRM	4
CC®	Jewelers' Standard	⅒ HP	18,000	CC	DD	FCT, SCT CFL-15	EM	MM	4
L	High Torque/ Low Speed	-	5,000	L	LB	FCT, SCT	EM	LM	5
R	Feedback- Full Torque at all speeds	⅒ HP	20,000	R	RB	FCR, SCR	EMR	-	5
K	CE Approved	⅙ HP	18,000	K	-	FCT-2CE	-	-	5

All Series and Models are available with 220/240 Volt Motors and Controls.
Series K is only available in 220/240 Volt.

Explanation of Suggested Retail Price

Motors and Speed Controls:
Example: CC®-FCT
Retail prices shown for machines include the motor, shaft and sheath, **and** speed control. The retail price for the CC Hang-Up machine in combination with the FCT speed control is (see listing on page 5).

Handpieces:
All handpieces shown on pages 9 – 12 are priced individually and should be added to the cost of the motor/speed control combination.

Prepackaged Flexible Shaft Rotary Power Tool Kits

2272 General Applications Kit

Includes: Series S Motor • No. 30 Handpiece
FCT Control
No. 20 Accessory Kit, Grease



2275 General Applications Kit

Includes: Series S Motor • No. 44T Handpiece
FCT Control
442, 443, 447 Collets, No. 20 Accessory Kit, Grease



2590 1/4 HP Series H Kit

Includes: Series H Motor • No. 44HT Handpiece
SCH Control
442, 443, 447 Collets, HK25 Accessory Kit, Grease, Motor Brushes



5200 Deluxe Woodcarving Kit

Includes: Series SR Motor • Nos. 28 and 44T
Handpieces • SCT Control
442, 443, 447, 602, 604 Collets, WK50 Accessory Kit, Grease,
Safety Glasses, Rotary Bur Stand



5240 Woodcarving Kit

Includes: Series SR Motor • No. 44T Handpiece
FCT Control
442, 443, 447 Collets, WK50 Accessory Kit, Grease



2274 Woodcarving Kit

Includes: Series S Motor • No. 44T Handpiece
FCT Control
442, 443, 447 Collets, WK50 Accessory Kit, Grease



2230 Jewelers Kit

Includes: Series CC Motor • No. 30 Handpiece
FCT Control
No. 10 Accessory Kit, Grease, AT-1 Tray



2240 Stone Setting Kit

Includes: Series L Motor • No. 18 Handpiece
FCT Control
No. 90 Accessory Kit in Stand, AT-1 Tray



5300 Woodcarving Kit

Includes: Series SRM Motor with dial control
No. 44T Handpiece
442, 443, 447 Collets, WK50 Accessory Kit, Grease



All kits above are available in 220/240 Volt at same prices.

H Hang-Up Style



H-FCH
H-SCH
H-EMH

See Page 2
for Series H
2590 Kit

HM Bench Style with built-in control



HM

HB Bench Style



HB-FCH
HB-SCH
HB-EMH

Also available in 220/240 Volt at same prices. Please Specify.

SERIES H Speed Controls and Handpieces

SCH-1



SCH-2
220/240 V

Foot Operated Control in
Cast Iron Housing

FCH-1



FCH-2
220/240V

Foot Operated Control in
Plastic Housing with extra
wide design

EMH-1



EMH-2
220/240V

Manual Control



25H
Comes with 1/8" & 1/4" Collets.
See Collet Set No. 103000 on Page 9



30H



44HT
Comes with 1/8" & 1/4" Collets
See Collet Set No. 440 on Page 9

118 HORSEPOWER SERIES S

Ball Bearing Motor



S Hang-Up Style

See Page 2 for Series S 2272, 2274, and 2275 Kits
See Page 8 for Speed Control Descriptions

S-FCT
S-SCT
S-EM

SM Bench Style with built-in control



SM

SB Bench Style



SB-FCT
SB-SCT
SB-EM

Also available in 220/240 Volt at same prices. Please specify.

118 HORSEPOWER REVERSIBLE SERIES SR

Ball Bearing Motor



SR Hang-Up Style

See Page 2 for Series SR 5200 and 5240 Kits
See Page 8 for Speed Control Descriptions

SR-FCT
SR-SCT
SR-EM

SRM Bench Style with built-in control



See Page 2 for Series SRM 5300 Kit

SRM

SRB Bench Style



SRB-FCT
SRB-SCT
SRB-EM

Also available in 220/240 Volt at same prices. Please specify.

110 HORSEPOWER SERIES CC®

Ball Bearing Motor



CC® Hang-Up Style

See Page 2 for Series CC 2230 Kit
See Page 8 for Speed Control Descriptions

CC-FCT
CC-SCT
CC-CFL
CC-EM

MM Bench Style with built-in control



MM

DD Bench Style



DD-FCT
DD-SCT
DD-CFL
DD-EM

Also available in 220/240 Volt at same prices. Please specify.

High Torque/Low Speed (0-5000 RPM) SERIES L Permanent Magnet/ Ball Bearing Motor



L Hang-Up Style

See Page 2 for Series L 2240 Kit
See Page 8 for Speed Control Descriptions

L-FCT
L-SCT
L-EM

LM Bench Style with built-in control



LM

LB Bench Style



LB-FCT
LB-SCT
LB-EM

Also available in 220/240 Volt at same prices. Please specify.

Full Torque 1110 HORSEPOWER SERIES R Ball Bearing Motor



R Hang-Up Style

See Series R FCR, SCR and EMR Controls on Page 8

R-FCR
R-SCR
R-EMR

RB Bench Style



RB-FCR
RB-SCR
RB-EMR

Speed Controls for Series R Machines

The Series R Hang-Up and RB Bench Style Models require special speed controls. These controls look the same as the other units, but have different mechanisms and distinct part numbers.

When ordering controls for the R or RB, please use the FCR-1A, SCR-1A, and EMR-1A Part Numbers shown on Page 8.

Also available in 220/240 Volt at same prices. Please specify.

116 HORSEPOWER SERIES K Ball Bearing Motor

New



K Hang-Up Style
220/240 Volt



K-FCT-2CE
Motor With Foot Control

Series K comes with FCT-2CE Foot Control with RFI filter



FCT-2CE
Foot Control Only

Series K Hang-Up Style

The Series K meets all CE electrical and safety requirements. It can only be used with the FCT-2CE foot control. See page 8 for foot control power cord options.

All Foredom interchangeable handpieces on pages 6 and 7 can be used with the Series K machine. Slip joint handpieces cannot be used with Series K machine.

General Purpose

8  8 comes with 3/32" (2.35mm) and 1/8" (3.18mm) collets

New

28  28 comes with 3/32" (2.35mm) and 1/8" (3.18mm) collets



30°  30° comes with #0 Jacobs® chuck with 0-5/32" (4mm) capacity

44T  44T comes with 3/32" (2.35mm), 1/8" (3.18mm), and 1/4" (6.35mm) collets

Hammer

15  15 comes with threaded anvil point

Heavy Duty

25  25 comes with 1/8" (3.18mm) and 1/4" (6.35mm) collets

25C  25C comes with #0 Jacobs® chuck with 0-5/32" (4mm) capacity

Speed Increasing

35  35 comes with 1/8" (3.18mm) collet unless otherwise specified

Quick Change

7A  7A is suitable for use only with 3/32" (2.35mm) shank burs or mandrels. For light/intermittent use only

Quick Release Push-Pull Action 7A and 7AD Handpieces



To insert accessory, pull handpiece grip back as far as it will go and insert. Then, push front portion of handpiece forward firmly.

10  Quick Change 10 is suitable for use only with 3/32" (2.35mm) shank burs or mandrels

Quick Release Lever Action Nos. 10 and 10D Handpieces



To insert accessory, rotate lever 180° toward back end of handpiece. Insert, and move lever forward 180° into locked position.

18  Quick Change 18 is suitable for use only with 3/32" (2.35mm) shank burs or mandrels

Press-to-Release Lever Nos. 18, 18D, and 18SJ Handpieces

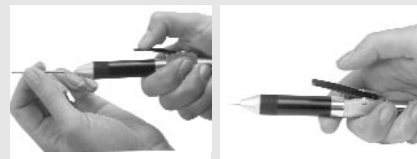

Simply push lever down to open collet ... release lever to lock in bur.

New

52  52 Comes with 3/32" (2.35mm) collet

New

53  53 Comes with 1/8" (3.175mm) collet

Quick Release Push-Pull Action 52, 52SJ, 53, and 52D Handpieces



Simply push to open chuck, insert accessory and pull to close and lock.

Angle Head



55A comes with 2 latch-type mandrels



56A comes with 2 latch-type mandrels

Angle head handpieces can only be used with latch type accessories

Duplex Connection Handpieces

The Foredom Duplex Spring Connection provides extra flexibility in the handpiece itself where more precise control for delicate work is required. The spring drive is of special steel, double wound, tubular construction and is protected by a flexible spring cover. Replacement springs (Part No. 76) are available and can be installed by the user.

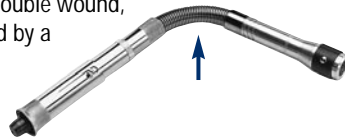

7AD is suitable for use only with 3/32" (2.35mm) shank burs or mandrels. For light/intermittent use only



8D comes with 3/32" (2.35mm) and 1/8" (3.18mm) collets



Quick Change 10D is suitable for use only with 3/32" (2.35mm) shank burs or mandrels



15D comes with threaded anvil point



QuickChange 18D is suitable for use only with 3/32" (2.35mm) shank burs or mandrels



Quick Change 52D is suitable for use only with 3/32" (2.35mm) shank burs or mandrels



55D comes with 2 latch-type mandrels



56D comes with 2 latch-type mandrels

Slip Joint Handpieces for European Machines

General Purpose



8SJ comes with 2.35mm (3/32") and 3mm collets



28SJ comes with 2.35mm (3/32") and 3mm collets



30SJ comes with #0 Jacobs® chuck with 0-4mm (5/32") capacity



44TSJ comes with 2.35mm (3/32"), 3mm, and 6mm collets

Quick Change



Quick Change 18SJ is suitable for use only with 2.35mm (3/32") shank burs or mandrels



Quick Change 52SJ is suitable for use only with 2.35mm (3/32") shank burs or mandrels

Hammer



15SJ comes with threaded anvil point

Speed Increasing

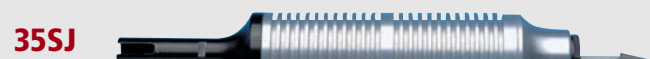

35SJ comes with 3mm collet unless otherwise specified

Slip joint handpieces above will fit on all European made flexible shaft machines with "slip joint" connections. They cannot be used with the standard "QD" (quick disconnect) style flexible shaft on all Foredom flexible shaft machines. A European style flexible shaft and sheath is available to replace the standard shaft and sheath on all Series of Foredom machines except the Series H.

Order Part No. 10812 \$125.00

Controls for *SERIES S, SR, CC, L, and R*

FCT
Electronic Foot Control
Heavy Duty Plastic Housing

FCT-1 110V



SCT
Electronic Foot Control
Metal Housing

SCT-1 110V



CFL-15
Carbon Pile Foot Control
Metal Housing

CFL-15 110V



EM
Electronic Manual Control
Plastic Housing

EM-1 110V



For Series R & RB Only:
FCR-1A 110V

For Series R & RB Only:
SCR-1A 110V

Not for Use with Series R

For Series R & RB Only:
EMR-1 110V

220/240 Volt Control Power Cords and Plugs



The standard 3 prong U.S. style plug will be supplied on all 220/240 volt controls unless specified. If you prefer British, Continental European, or Europlug, please specify and add \$3.00 to the price of the control. If you prefer a cord with no plug, specify

Part No. **OPTION 20**

British



Part No. **OPTION 21**
with internal fuse 220/240V

Continental European



Part No. **OPTION 22**
with 2 prongs and grounding hole

Europlug



Part No. **OPTION 23**
with 2 prongs 220/240V

Maintenance Supplies

Maintenance Kits

Maintenance Kits are suitable for both 110 & 220V units, except where noted. Kits for ball bearing motors contain a shaft, pair of motor brushes, grease & operating manual. Sleeve bearing motor kits have the same contents plus oil.

- MK-8** Maintenance Kit for Ball Bearing S, SB, SM, SR, SRB, SRM motors .
- MK-9** Maintenance Kit for Ball Bearing CC, DD & MM 110V motors.....
- MK-9A** Maintenance Kit for Ball Bearing 220V CC motors.....
- MK-6A** Maintenance Kit for Ball Bearing R & RB motors
- MK-1** Maintenance Kit for Sleeve Bearing Motors
R, RB, RM, CC, DD & MM

Lubrication Supplies

- 10005** Freedom Motor & Handpiece Oil in Hypodermic Dispenser
- 10010** Freedom Motor & Handpiece Oil in 2 oz. container
- 10006** Freedom Flexible Shaft Grease in 1 oz. container

Motor Brushes

Priced Per Pair. Suitable for 110 & 220V units except where noted.

- 2019P** Pair of Motor Brushes for Series S, SB, SM, SR, SRB, SRM motors, Series H, HB, HM motors, and AG-1, AG-2
- 119P** Pair of Brushes for CC, DD, MM motors 110V only
- 117P** Pair of Brushes for R, RB, EE, GG & MMG motors, and CC220V
- 229P** Pair of Brushes for B&G Models 1 & 5, Series F motors
- 262P** Pair of Brushes for BL-1
- 319P** Pair of Brushes for Series L & PG

Replacement Shafts and Sheaths

Inner Shafts

- 93** Inner Shaft for Series S, SR, CC, R, L, and PG motors.....
- 96A** Inner Shaft for Series EE motors.....
- 97** Inner Shaft for Series F motors.....

Outer Sheaths (standard material)

- 77** Outer Sheath for Series S, CC, R motors
- 80** Outer Sheath for Series EE motors
- 82** Outer Sheath for Series F motors

Outer Sheath (neoprene material)

- 76N** Outer Sheath for PG motor
- 77N** Outer Sheath for Series SR and L motors
and optional for Series S, CC and R motors
- 80N** Optional Outer Sheath for Series EE motors

Supplies for Series H

Heavy Duty Shaft, Sheath, Complete Assembly and Motor Brushes

- 10805** Inner Shaft for Series H motors.....
- 10802A** Outer Sheath for Series H motors, includes 10822.....
- 10822** Silencer for Series H motors
- 10804B** Complete Assembly (10805, 10802A & 10822).....
- 2019P** Motor Brushes – Priced Per Pair

Handpiece Collets and Accessories

Part No.	Description	Part No.	Description
600	Set of 4 Collets (see below) For Handpieces Nos. 8, 8D, 8SJ, 28, and 28SJ Also for use in RD-1, MC-1, and CHA-1		Collets below fit Handpieces Nos. 25, 25H, 35, & 35SJ
601	1/32" (.8mm) Collet	103116	1/16" (1.6mm) Collet
602	1/16" (1.6mm) Collet	103115	3/32" (2.35mm) Collet
603	3/32" (2.35mm) Collet	103114	1/8" (3.18mm) Collet
604	1/8" (3.18mm) Collet	103113	3/16" (4.8mm) Collet
605	3mm Collet for Handpieces and Adapters above (The 605 Collet is not included in No. 600 Set)	103112	1/4" (6.35mm) Collet
		103124	3mm Collet
		103126	4mm Collet
		103119	6mm Collet
440	Set of 7 Collets (see below) For Handpieces Nos. 44, 44T, 44TSJ, and 44HT Also for use in Adapter CHA-4	103000	Set of 5 Collets for Handpieces Nos. 25 & 25H consists of 1/16", 3/32", 1/8", 3/16", 1/4"
441	1/16" (1.6mm) Collet	72	Chuck key for Handpieces Nos. 30, 30SJ, 30H, and 25C .
442	3/32" (2.35mm) Collet	10420	Chuck key holder for Handpieces Nos. 30, 30SJ, and 30H
448	3mm Collet.....	10586	Wrench Assy. for Handpieces Nos. 8, 8D, and 8SJ
443	1/8" (3.18mm) Collet	10588	Pin and chuck wrench for Handpiece Nos. 28 and 28SJ
444	5/32" (4mm) Collet	67	Pin & chuck wrench for Handpiece Nos. 44, 44SJ, & 44H.....
449	6mm Collet	103117	Pin & chuck wrench for Handpiece Nos. 35, 35SJ, 25, 25H, 44T, 44SJ, and 44HT.....
447	1/4" (6.35mm) Collet	76	Duplex spring.....
445	3/16" (4.8mm) Collet (Not Included in 440 Collet Set)	76B	Package of 12 Duplex Springs
	Points for Nos. 15 and 15D Handpieces	10151	Collet for Handpieces Nos. 7, 7D
10177	Anvil Point for Handpieces Nos. 15 and 15D	7A18CD	Collet for Handpieces Nos. 7A, 7AD
10212	Carbide stylus for Handpieces Nos. 15 and 15D	703	Collet for Handpieces Nos. 18, 18D, and 18SJ
R15PT	Pavé Point for Handpieces Nos. 15 and 15D.....		

MC2 Micro Chuck

Used for 60 to 80 wire gauge drills in drill press or handpiece. Has 1/8" shank. Can be used in Nos. 8, 8D, 8SJ, 28, 28SJ, 44T, and 44TSJ handpieces.



M-50

For use with 70 to 80 wire size drills. Has 3/32" shank suitable for use with No.18 and all other Foredom handpieces.



Handpiece Accessories

G-30 Handpiece Grip

Cushion grip for Nos. 30° and 30SJ handpieces.



CKH-1 Chuck Key Handle



For Nos. 30°, 25C, 30H handpiece users.

Comes with #0 chuck key in handle.

AT-1 Handpiece/Accessory Tray



Handpiece Holder

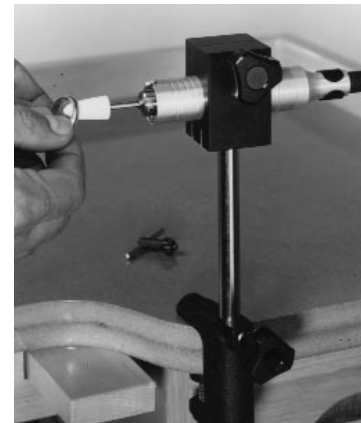

Handpiece Holder HH-30

HH-30 for Nos. 30°, 30H, 44, 44T, & 44HT handpieces. Handpiece holder comes complete with handpiece clamp, rod & BC-1 bench clamp.

Bur Holders

Universal- All Size Burs



10080 Rotating Bur Holder

Rotating bur holder stores and organizes all size accessories including 1/16", 3/32", 1/8", and 1/4" shanks. This compact unit measures 7" wide by 4" high and holds 69-3/32" or 1/8" burs (in 2-step holes), 12-1/4" burs, and 45-1/16" burs. (Burs not included.)

For 3/32" and 1/8" Burs



10088 Bur Holder

Plastic stand with clear cover for storing 3/32" and 1/8" shank accessories. Has 24 holes for each size shank. Measures 2 1/8" in dia. by 2 1/2" high. Holds burs up to 2" long. (Burs not included).

For 3/32" and 1/8" Burs



10085 Rotating Bur Holder

Rotating bur holder for organizing and storing rotary accessories. Measures 6 1/4" in dia. by 4" high. The 10085 holds 108-3/32" burs and 48-1/8" shank burs on bottom row.

Safety Glasses



SG-2

Distortion-free, clear polycarbonate lenses with wrap-around side shields and anti-glare brow guard. These glasses are lightweight and comfortable and may be worn over prescription glasses.



SG-3

These clear, polycarbonate glasses have a more contemporary styling with unitary lens design, soft-fit nose bridge, and indigo blue colored temples. Temple length can be fully adjusted, and side shields can be removed. Temple ends are slotted to accommodate neck cords.

Always wear proper eye protection when operating Foredom and other power tools

Foot Switch

FCG On/Off Foot Switch

Momentary On Complete with 18" cord with receptacle plug and 6' cord with 3-prong plug.



For use with flexible shaft machines where user wants only sustained full speed in operation. Also for use with scroll saws, drill presses, or other stationary power tools that the user wants to turn on and off without using the manual switch. Rated for 110/130V or 220/240V, 1/4HP, 5 amp max. motors.

Motor Hangers

MH-3
MH-4



The MH-3 & MH-4 Double Motor Hanger models have a T-rod at the top for hanging two motors, and feature full swivel & locking screw.

The MH-3 comes with the BC-1 mounting clamp, shown below, for attaching to bench tops, and the AT-1 Accessory Tray, on page 9.

The MH-4 comes with base BC-2 shown here and below, that screws onto top or side of bench.

Both come with HR-1 handpiece rest.

MH-5
MH-6



The MH-5 comes with the BC-1 mounting clamp, shown here and below, for attaching to bench tops, and the AT-1 Accessory Tray, shown on page 9.

The MH-6 comes with base (BC-2 shown below), that screws onto top or side of bench.

Both come with HR-1 handpiece rest.

New!
MH-7

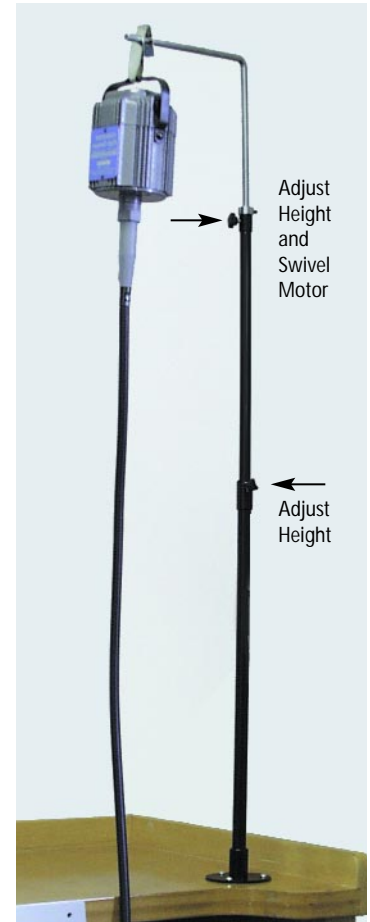

The New MH-7 has a telescoping design for easy height adjustment. The pole screws allow the operator to adjust motor height and to swivel motor position.

Comes with a permanently fixed mounting clamp and 3 screws for attaching to bench tops.

HR-1 Handpiece Rest

Slip this handy item onto your Foredom® or other motor hanger with 1/2" or smaller diameter pole and secure your handpiece when not in use. The back cut-out conveniently holds a motor cord away from work.

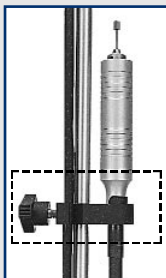

BC-1 Bench Clamp

Clamps to any bench up to 1 3/4" thick and holds all motor hanger and handpiece holder rods.



BC-2 Base

Screws or bolts to side or top of bench for permanent mounting. Holds all motor hanger and handpiece holder rods.

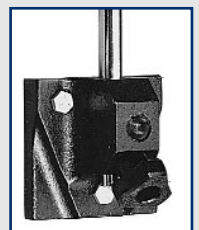

Drill Presses

DP-95 Precision Drill Press



The DP-95 converts your flexible shaft machine into a precision drilling and wax modeling tool.

Designed for use with Nos. 30[®], 30H, 44, 44T, and 44HT handpieces.

Features:

- Dial indicator measurable in millimeters for setting drilling or cutting depth—graduated by $\frac{1}{100}$ mm.
- Has 2" throat capacity and stroke length up to $1\frac{1}{4}$ ".
- Adjustable head with locking mechanism.
- Rise and fall, rack and pinion table with locking mechanism.
- 8" x $3\frac{1}{2}$ " table with machined flat surface and center hole.

Can be used with any Foredom motor. The DP-95 is especially well suited for use in both drilling and wax modeling applications with the Series L, high torque/low speed (5,000 rpm) motor.



DP-39 Drill Press

Has same dial indicator and adjustable head with locking mechanism as the DP-95 for precise hole drilling and milling applications. The work holding table moves up and down on post or can be swung away for drilling large pieces.



DP-30 Drill Press

A rugged and precise stand which converts your Foredom[®] flexible shaft power tool into a drill press. The sturdy, all metal stand is fully adjustable, has a 2" throat capacity and a stroke length up to $1\frac{1}{4}$ ".

The DP-95, DP-39, and DP-30 are designed for use with Nos. 30[®], 30H, 44, 44T and 44HT handpieces and any Foredom[®] flexible shaft machine.

Multi-Angle and Mini Vises

Multi-Angle Vises

Made from sturdy cast metal, these vises are ideal for holding many different objects in any position. The heads rotate 360° and lock at any angle. Vises have "v" grooved metal jaws for holding round pieces such as pipes, dowels, and rods. Come with removable soft jaw pads to protect delicate work pieces.



F37216

Jaw width: 3"
Jaw capacity: $2\frac{1}{4}$ "
C-clamp type mounting attaches firmly and easily to a workbench up to 2" thick.

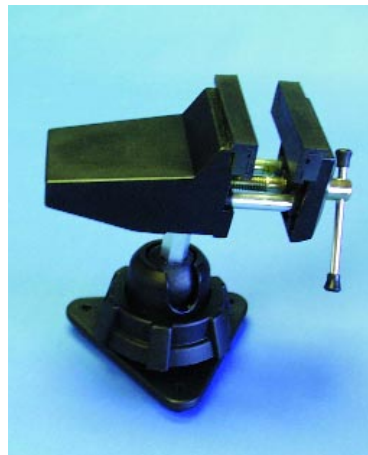

F37234

Jaw width: $2\frac{3}{4}$ "
Jaw capacity: $2\frac{3}{4}$ "
Metal base has rubber feet that can be removed for permanent mounting onto the work surface with screws or bolts.

Mini Vise F37200



Zinc die cast mini vise firmly grasps small workpieces for precision drilling on the table top. Has horizontal and vertical "V" grooves for holding small round pieces.

Jaw width: $1\frac{3}{8}$ "
Jaw capacity: $1\frac{1}{4}$ "

BL-1 Bench Lathe

BL-1 Bench Lathe



Ball Bearing
1,800 - 7,000 RPM

A powerful variable speed bench lathe in a compact size suitable for use at the workbench. Comes complete with TM-3 and TM-4 Tapered Spindles, CHA-4 Collet Holder with 3/32" and 1/4" collets, WM-4 Wheel Mandrel, and screwdriver.

Also available in 220/240 Volt AC
Specify: **BL-2**

3340 Workshop/Lab Kit

This great kit is a lathe and flexible shaft machine in one. Includes the BL-1 Lathe with tapered spindles and collet holder above, plus the B0-14N Flexade® with 1/4" coupling and neoprene sheath, 44T handpiece, 3/32", 1/8", and 1/4" collets, extra pair of motor brushes, and screwdriver.

See Flexade description to the right.
Also available in 220/240 Volt.
Specify **3340-2**

New Workshop/Lab Kit!



Accessories for BL-1 and B&G Grinders

Spindles, arbor, collet holders, and mandrels have 1/4" diameter holes with two set screws for use on 1/4" motor shafts.

Tapered Spindles



TM-3 (left hand)
TM-4 (right hand)

Wheel Mandrel



WM-3 (left hand)
WM-4 (right hand)

Collet Holders



CHA-1 with 3/32" collet
CHA-4 with 1/4" collet

Flexade®

Convert your lathe into a flexible shaft machine with a Series B Flexade. Any Foredom handpiece can be attached to the Flexade except Nos. 25H, 30H, 44H, and 9D. Specify motor coupling size (1/4", 1/2", 3/8", or 5/16"). 1/4" coupling supplied if not otherwise specified.



Price is for Flexade alone. (See pages 6 and 7 for handpiece prices).

Standard Sheath	Neoprene Sheath
-----------------	-----------------

1/4" Coupling	B0-14	B0-14N
1/2" Coupling	B0-12	B0-12N
3/8" Coupling	B0-38	B0-38N
5/16" Coupling	B0-516	B0-516N

High Speed Bench Grinders

B&G High Speed Bench Grinders 1/15 HP



Ball Bearing
17,000 RPM

Model Nos. **1 B&G** with Electronic Manual Speed Control
5 B&G with FCT Electronic Foot Control

Available in 220/240 Volt at Same Price. Specify No. 1 B&G-2 or No. 5 B&G-2

PowerGraver® Kit and Components

Kit No. 2293

The 2293 PowerGraver Kit provides a power assist to stone setting and engraving operations. It's PG motor is designed for high torque/low speed applications, and features a totally enclosed housing with permanently lubricated ball bearings for quiet, trouble-free performance.

The 9D handpiece works and feels like a hand engraving tool with the added advantages of greater control and the ability to adjust the impact force.

The unit comes equipped with a special, extra flexible neoprene sheath and a 6' long power cord.

The PowerGraver is ideal for bead, prong, channel, hammer and bezel setting, as well as decorative and engraving work.

A 32-minute instructional video is included, along with a set of accessories and maintenance items described below.



Kits Nos. 2293, 2293-2, 2295, and 2295-2 may be ordered without the set of 4 gravers, engraving and anvil points at a savings of \$30.00. Add **OPTION 91** to end of part number when ordering.

PowerGraver Accessories

Collets: Nos. 602, 603, 604



Optional Pavé Diamond Point– 3/32" No. R15G



Anvil– 3/32" Shank No. 10177P



Carbide Point– 3/32" shank No. A-EP165P



Ideal Uses:
Bead
Prong
Channel
Hammer & Bezel Setting

Engraving & other
Decorative Work

Kit No. 2293

Includes:

Series PG Motor

No. 9D Handpiece

EMG Dial Control

FCG Foot Switch

602, 603, and 604 Collets

Set of 4 Gravers

Anvil Point, Engraving Point with Carbide Tip Grease, Handpiece Oil.

Also includes 32-minute instructional video.

Available in 220/240V at same price.

Please specify Kit No. 2293-2

Kit No. 2295

Includes all product listed above except has FCT-1 foot control in place of EMG Dial Control and FCG Foot Switch.

Kit No. 2295-2 for 220/240V

Includes all product listed above except has FCH-2 foot control in place of EMG Dial Control and Foot Switch.

PowerGraver Video is Available Separately:

VID 103 NTSC

VID 104 PAL



Optional Foot Speed Control FCT-1

For use in place of EMG and FCG with PG Motor.

For 220/240V, Specify **FCH-2**

Sharpener/Honer with Fixture

Kit No. 2225 Sharpener/Honer with Fixture

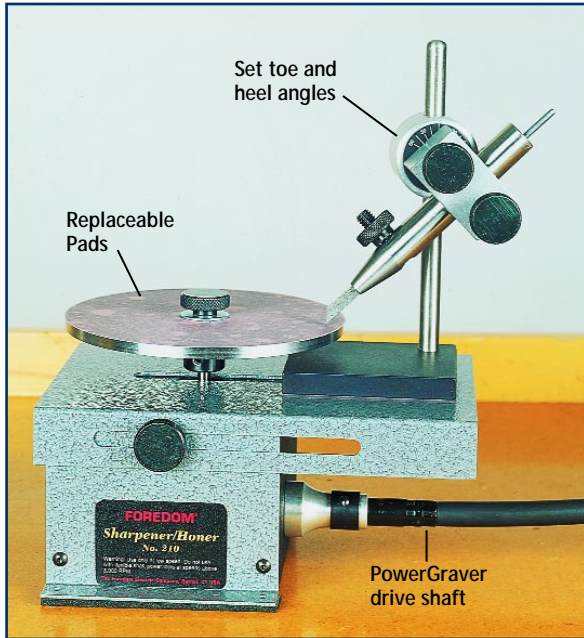

Ideal for use with the PowerGraver for Sharpening and Polishing Gravers

Sharpener/Honer features:

- Operates off the power of the PowerGraver with a 3:1 gear reduction to run at speeds between 300 and 900 rpm. Can be used with Series L machines at 1/2 speed or less, and with Series S and CC models at less than 3,000 rpm's.
- Table adjusts for right and left handed operators.
- Uses double sided wheels and 3M adhesive pads available in 6 micron grades shown below.

Fixture features:

- Has vertical and horizontal indexing adjustments.
- Makes both toe and heel angles required for modifying and precise resharping of gravers.

Kit No. 2225 Sharpener/Honer with Fixture

No. 210 Sharpener/Honer

No. 220 Fixture

No. 215 Double Sided 6" Replacement Wheel

3M Aluminum Oxide Replacement Pads

No. A-HLD3 (Grade 3)

No. A-HLD15 (Grade 15)

No. A-HLD5 (Grade 5)

No. A-HLD30 (Grade 30)

No. A-HLD9 (Grade 9)

No. A-HLD60 (Grade 60)

PowerGraver® Components

No. 9D Handpiece



This chuck type handpiece has a special quick disconnect that fits only the PG motor sheath. It has an adjusting ring that changes the impact force and a palm rest that provides the comfort and "feel" of a hand engraving tool.

Comes with 3 interchangeable collets (1/16", 3/32", 1/8").



**FCG
On/Off Foot
Switch**

For use on 110V
or 220V



**PG Motor
with 36"
Neoprene Flexible
Sheath**

Has Full Two Year
Warranty



**EMG
Dial Control**

Micro Motor Kit and Components

1045 Micro Motor Kit

45,000 RPM



Micro Motor Components

MH-145 Micro Motor Handpiece

6" overall length • 5/8" grip dia., 1" motor dia. • 7.5 oz/213 gr.
1.5 amps (110V) .75 amps (220V)

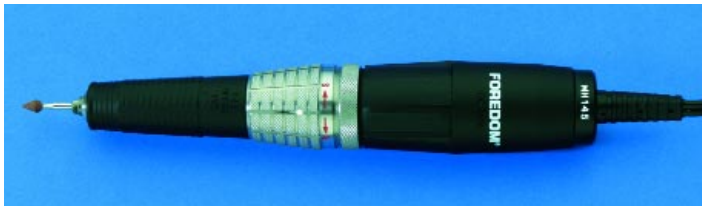

High speed handpiece with slender, contoured grip for precise and very high speed work. Use with diamond and other accessories rated for at least 45,000 RPM. Fan cooled, brush type continuous duty motor runs cool and vibration-free. Quick release rotary type chuck and permanently lubricated and shielded ball bearings require no lubrication. Comes with 3/32" (2.35mm) and 1/8" (3.175mm) collets.

FM3545 Control



Provides variable speed with dial or foot pedal. Has front panel On/Off, Manual/Foot and Forward/Reverse switches and Power-On light. For use with MH-145 and MH-011 handpieces only. Built-in over-load protection. 6' long power cord with 3-prong plug.

Also available in 220/240V at same price. Please specify **FM3545-2** when ordering.

The 1045 Micro Motor is ideal for high speed applications, such as bright cutting in jewelry making and fine detailing in wood carving. The simple coil connection between the handpiece motor and control box allows for complete freedom of movement that is not available when using a flexible shaft machine.

The 1045 Micro Motor operates at speeds up to 45,000 rpm in both forward and reverse rotation. Speed can be adjusted from low to full speed using the dial on the control box, or with the foot pedal.

Bur changes are quick and easy with a simple twist of the handpiece locking ring. A selection of collet adapters (see below) is also available for simplifying changes between accessories with different shank sizes.

The 1045 Kit Includes:

MH-145 Handpiece, FM3545 Control, FC-2000 Foot Control, AT-1 Handpiece Tray, 1/8" and 3/32" Collets, Safety Glasses, and Spare Pair of Motor Brushes.

1045-2 Micro Motor Kit - 220/240 Volt version of kit. Please specify when ordering.

1045X Kit - Includes all items in 1045 Kit except for the FC-2000 Foot Control.

FC-2000 Foot Control



Solid state control in heavy duty plastic housing. Varies handpiece speed from off to full speed while control selection switch is in FOOT position only.

Replacement Collets and Motor Brushes

1/8" Collet	HP813517
3/32" (2.35mm) Collet	HP813516
3mm Collet	HP813518
Motor Brushes for MH-135 (Pair)*	HP813514
Motor Brushes for MH-145 (Pair)	HPL4-304

* MH-135 Handpiece has been discontinued, however, replacement collets and motor brushes, as indicated above, are still available.

Adapter Collets

Use collet adapter with different shank size accessories without having to change collets.



HPL4-3234:	1/8" to 1/16"
HPL4-3235:	3mm to 3/32"
HPL4-3236:	1/8" to 3/32"

Micro Motor Hammer Kit and Components

1011 Micro Motor Hammer Kit



The 1011 Micro Motor is ideal for stone setting applications, including channel setting, and other decorative and engraving techniques requiring reciprocating action.

The force of the impact can be adjusted from light to full by turning the metal ring while the handpiece is either off or running. The speed of the hammer action can be varied from 0 – 5,000 strokes per minute with the manual dial on the control box, or the optional foot speed control.

The 1011 Kit includes the MH-011 Hammer Handpiece, FM3545 Control and the accessories shown below. The FC-2000 foot control must be ordered separately.

1011-2 Micro Motor Kit - 220/240 Volt version of kit. Please specify when ordering.

Micro Motor Components

MH-011 Micro Motor Hammer Handpiece

6¼" overall length • 9/16" grip dia., 1" motor dia. • 13 oz/369 gr. 1.5 amps (110V) .75 amps (220V)

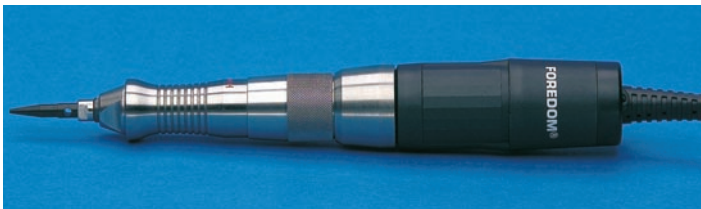

Hammer handpiece with slender, contoured grip and impact adjustment ring for precise hammering work. Operates from 0 – 5,000 strokes per minute.

FM3545 Control



Also available in 220/240V at same price. Please specify **FM3545-2** when ordering.

Provides variable speed with dial or optional foot pedal. Has front panel On/Off and Manual/Foot switches, and Power-On light. The FM3545 is the same control for both the MH-011 hammer and MH-145 rotary handpieces. With the MH-011 attached, the control must be used in the Forward position only.

The control has built-in overload protection. 6' long power cord with 3-prong plug.

The 1011 Kit Accessories:

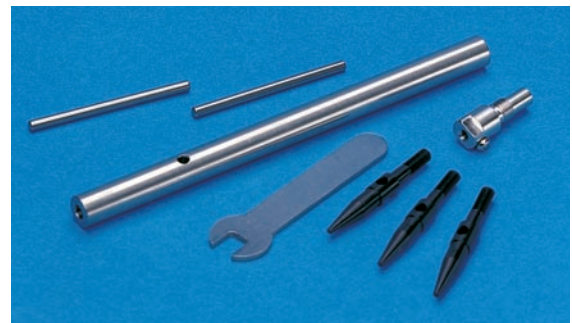

3– Anvil Points with Threaded Shanks, 1– Anvil Point Adapter for Non-threaded Shank Accessories (2.35mm), Open End Wrench (5mm), 2– Pins used to tighten Anvil Points, 1– Anvil Point Holder used for shaping the point.

Also includes AT-1 Handpiece Tray, Safety Glasses, and Spare Pair of Motor Brushes.

Accessories and Motor Brushes

Anvil Point with Threaded Shank	10177K
Anvil Point Adapter for Threaded Anvil Point	H8-32
Adapter for Non-Threaded Shank Accessories	H8-35
Open End Wrench (5mm)	H8-38
Pavé Diamond Point	R146
Carbide Engraving Point	EP165
Motor Brushes for MH-011 (Pair)	HP813514

FC-2000 Optional Foot Control



Solid state control in heavy duty plastic housing. Varies handpiece speed from off to full speed while control selection switch is in FOOT position only.

FOREDOM ALLSET™ Stone Setting Guide

Set Stones the Easy Way with the Foredom ALLSET™



The Allset™ Stone Setting Guide is great for Channel, Prong, Pavé, Bezel and other stone setting techniques. The guide allows you to set stones faster and more accurately. Both highly skilled and beginning stone setters will appreciate the advantages of this terrific tool.

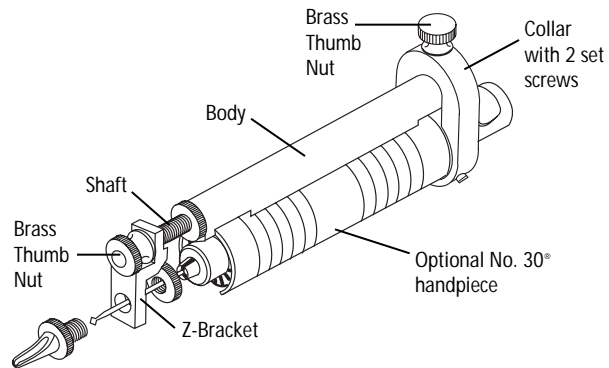
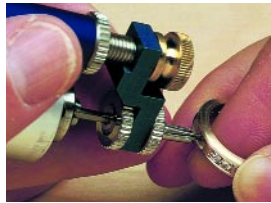

Allset™ Stone Setting Kits contain these basic items:

- Z-bracket with shaft
- Body
- Collar with set screws
- 2 Brass thumb nuts
- Allen Key
- 2 Finger Nuts
- Instruction manual

Kit 820 Master Kit with No. 30° Handpiece.

Includes basic items listed above plus the No. 30° handpiece, Prong Guide, Channel, Table, and Pavé Kits detailed below, and Allset Instructional Video.

Kit 825 Master Kit. This kit is the same as Kit 820 except it does not include the No. 30° handpiece.

Kit 810 Universal Kit with No. 30° Handpiece. Includes basic items listed above plus 6-Prong Guides (3mm, 4mm, 5mm, 6mm, 7mm & 8mm), Milling Table (35mm in dia.), 3-Pavé Guides (3mm, 3.5mm & 4mm), 2-Channel Guides, and Allset Instructional Video.

Kit 810SJ Universal Kit with No. 30SJ Handpiece.

This kit is the same as Kit 810 except it includes the No. 30SJ European slip joint handpiece in place of the standard No. 30° and a PAL version of the Allset Instructional Video.

Kit 815 Universal Kit. This kit is the same as Kit 810 except it does not include the No. 30° handpiece.

Kit 816 Universal Kit. This kit is the same as Kit 810SJ except it does not include the No. 30SJ handpiece.

Kit 826 Prong Guide Kit includes basic items listed above plus 13-prong-setting guides.

Kit 828 Channel Kit includes basic items listed above plus 3-channel setting guides (small & large radius for baguette, and double knife-edge for round stones).

Kit 830 Table Kit includes basic items listed above plus 4-milling table attachments.

Kit 832 Pavé Kit includes basic items listed above plus 7-pavé guides. (Does not include basic items listed above.)

Set 827 Prong Guide Accessory Set includes 13-prong setting guides. (Does not include basic items listed above.)

Set 829 Channel Accessory Set includes small and large radius guides for baguette and double knife-edge guide for round stones. (Does not include basic items listed above.)

Set 831 Table Accessory Set includes 4-milling table attachments. (Does not include basic items listed above.)

Set 833 Pavé Accessory Set includes 7-pavé guides. (Does not include basic items listed above.)

834 Z bracket and Shaft.

VID125 29 min. Instructional Video –NTSC version.

VID126 29 min. Instructional Video –PAL version.



Drill Holes for Pre-Set Signity Stones the Easy Way with the Foredom ALLSET™ Drilling Kit

Kits 8842 and 8843 contain Allset bracket and Z bracket and shaft that fit onto the Foredom No. 30° handpiece. The guide tip on the Z bracket can be locked into position after the correct drilling depth for the 2.00mm or 2.25mm drill is determined with the depth gauge. This enables the user of Signity Pre-Set Stones to make any number of correctly drilled holes in the workpiece.

Kit 8844 Drilling Kit with No. 30° Handpiece, hand-piece bracket, guide tip, depth gauge, and two 2.00mm drills in case.

Kit 8845 This kit is the same as Kit 8844 except that it has two 2.25mm drills in case.

Kit 8842 Drilling Kit with handpiece bracket, guide tip, depth gauge, and two 2.00mm drills in case.

Kit 8843 This kit is the same as Kit 8842 except that it has two 2.25mm drills in case.

Kit 8846 Drilling Set with guide tip, lock nut washer, and two 2.00mm drills.

Kit 8847 This kit is the same as Kit 8846 except that it has two 2.25mm drills.

87890 2.00mm drill.

87891 2.25mm drill.

87894 Depth gauge.

Air Turbine

350K Air Turbine Kit
 350,000 RPM
 Ultra High Speed Grinder



Ultra high speed air operated grinder for extremely rapid and precise material removal.

Includes:

Handpiece, Foot Pedal, Stand with Filter/Regulator, 12' Vinyl Tubing, Wrench, and Set of 3 Friction Grip (1/16" shank) Carbide Burs.

No. 900 Air Turbine Handpiece



Foot Pedal
 Turns air flow to handpiece on and off.

ACV



Stand with Filter Regulator

CP90030

Also has handpiece holder on right and left side.



Replacement Parts

Item	Part No.	Price Ea.
Turbine	HP90018	
Collet	HP90017	
Collet Wrench	HP90012	
Turbine Wrench	HP90013	

Air Grinder

Model 800 Air Grinder

30,000 RPM High Torque
 Finger Tip Control

Easy to Use and Economical to Operate.

Comes complete with a 6' heavy duty hose, 1/8" and 3/32" interchangeable collets, and wrenches. (Filter/Regulator/Lubricator not included.)



Model 800F

Model 800 Air Grinder with FRL-1 Filter/Regulator/Lubricator (as shown above).

Collets for Air Grinder

No. 600 Collet Set 601, 602, 603 & 604

- 601 1/32"
- 602 1/16"
- 603 3/32"
- 604 1/8"



605 3mm
 (not part of set)

Filter/Regulator/Lubricator

FRL-1



Product Repair and Warranty Information

Repair Service

Authorized repair service is available at the Foredom factory in Bethel, CT. Send items for repair to the factory marked "Attention: Repair Department". Enclose the item(s), a packing list, your address, telephone and/or fax number, and information regarding the problem or repairs required. Estimates of repair cost will be made upon request. It is our policy **not** to proceed with a repair without your approval if the cost (labor plus parts) is more than fifty percent of the cost for a new replacement. You will be notified by mail or fax and advised of the cost to repair and to purchase a new replacement. Please allow three business days for an estimate to be done and five to seven business days for repair work to be completed after we receive your approval to proceed.

Product Warranty

Foredom products are made to industrial standards to assure top performance and long life. The following products carry a One-Year Warranty:

- All Ball Bearing Flexible Shaft Motors
- BL-1 Polishing Lathe
- All Solid State Electronic Foot Controls
- Kits Nos. 2230, 2240, 2272, 2274, 2275, 5200, 5240, 5300

The PowerGraver® (PG) motor carries a Two-Year Warranty

All other Foredom power tools and attachments are warranted to be free of defects in material and workmanship for a period of 90 days from date of purchase by the user. These warranties do not cover breakage or damage caused by accident, abuse, or misuse and repairs required because of ordinary use and wear. Repair or replacement will be done at our option if the product is post-paid to our factory. We pay the return postage charges for all items repaired under warranty.

For more complete descriptions of the products featured in this Price List, including Foredom machines, handpieces, and speed controls. Please request—

Look to Foredom as the single best source for accessories—abrasives; cutters; Typhoon® carbides; ruby carvers; diamond points; felt, cotton, and chamois polishers; sanding accessories; drills and more. Please request—

This new catalog focuses specifically on accessories used by professional jewelers, including: setting burs, beading tools, step drills, diamond points, abrasives, brushes, sanding and polishing accessories, and more. Please request—

Another new catalog with a complete selection of accessories used in dental labs, including: Typhoon® carbide burs and sleeves, CeramCut Blue™ stones, steel burs, plated and sintered diamond points, abrasives, brushes, polishing buffs, and more. Request—

Catalog No. 370

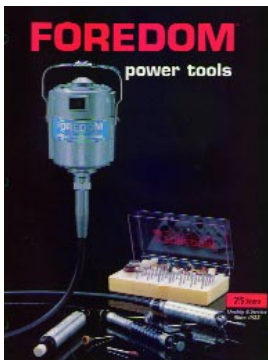

Catalog No. 325

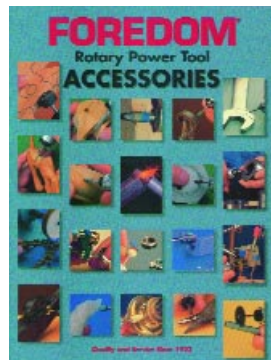

Catalog No. 370

Professional Jewelers Accessories	
FOREDOM	
Beading Tools	9
Step Drills	9
Mounted Abrasive Points	10
Unmounted Abrasives	11
Diamond Points & Bits	12
Mounted Brushes	13
Felt Burs	14
Miniature Carbide Burs	15
Sanding & Polishing Accessories	15
Buffs & Polishing Compounds	16-17
Waxers & Bar Holders	18
Waxers & Handpieces	19

Catalog No. 501

